

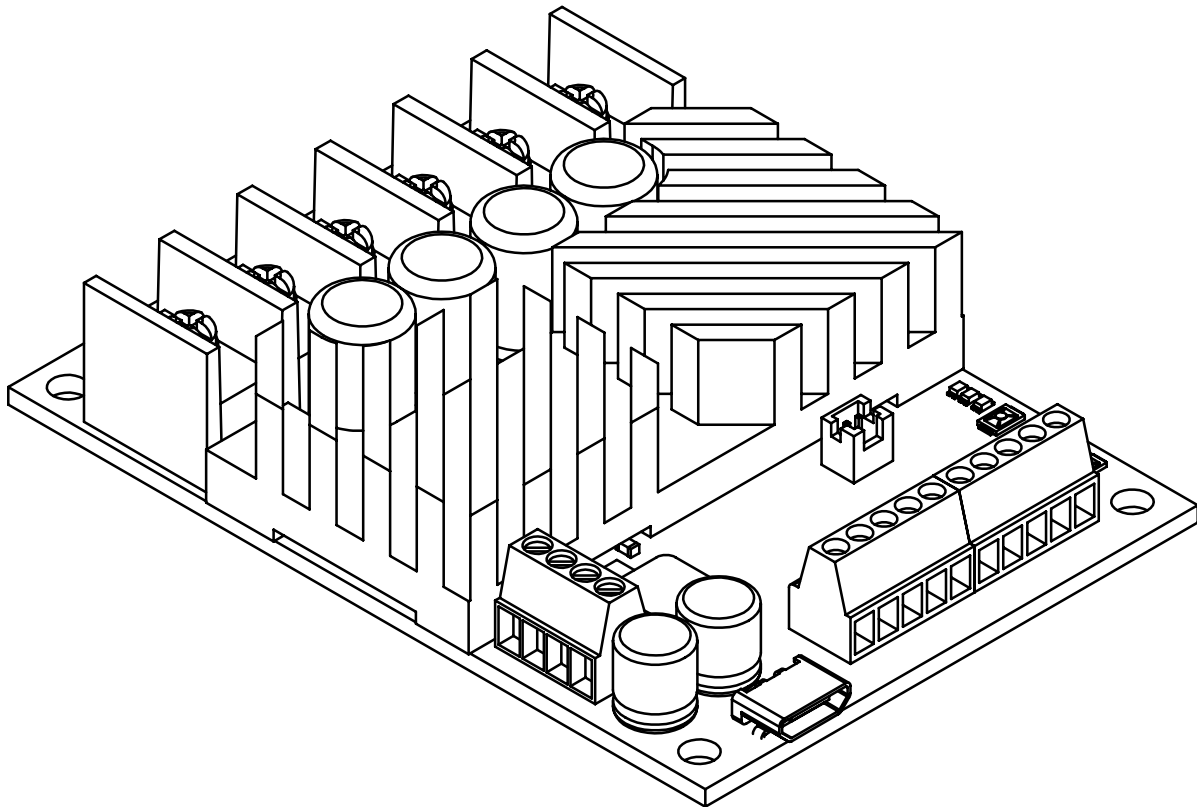

# MOTION CONTROL



**RoboClaw ST 2x45A, 34VDC Dual Channel  
Brushed DC Motor Controller**

**Data Sheet Version 2.2**

## Feature Overview:

- 60 Amps Peak Per Channel
- Channel Bridging Supported
- Dual Quadrature Decoding
- 19.6 million PPS Decoding
- Multimode Interface
- TTL Serial
- USB Port
- Analog Interface
- R/C Input Control
- Limit, Home and E-Stops
- Up to 34VDC Operation
- Cooling Fan With Automatic Control
- 3.3v Compliant Control Outputs
- 5v Tolerant Control Inputs
- Programmable Current Limiting
- Programmable Voltage Clamping
- Closed and Open Loop Operation
- Auto Tuning PID Feature
- Mixed Control Modes
- Data Logging
- Diagnostic LEDs
- Field Firmware Updates
- Regulated 5VDC, 3A User Available Output
- Over Voltage and Under Voltage Protection
- Easy Tuning, Monitor and Setup with PC utility

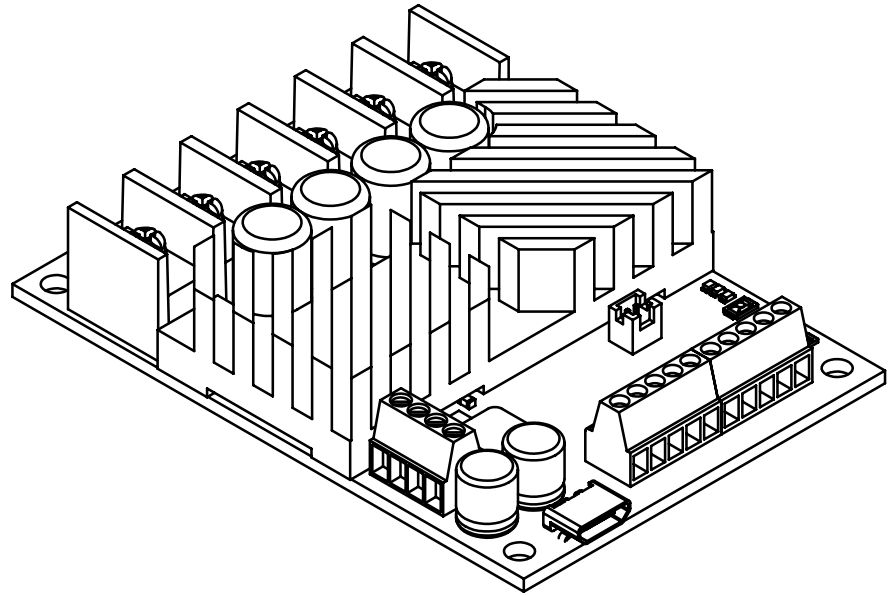

## Device Overview

The RoboClaw is an intelligent, high performance motor controller designed to control dual brushed DC motors. It can be controlled from USB, RC radio, PWM, TTL serial, analog and microcontrollers such as an Arduino or Raspberry Pi.

RoboClaw automatically supports 3.3V or 5V logic levels, travel limit switches, home switches, emergency stop switches, power supplies, braking systems and contactors. A built-in switching mode BEC supplies 5VDC at up to 1.2 Amps for powering user devices. In addition power supplies can be utilized by enabling the built in voltage clamping control feature.

A wide variety of feedback sensors are supported. This includes quadrature encoders, potentiometers and absolute encoders which can be easily configured using the available auto tune function. With sensors, two brushed DC motors can be controlled in closed loop mode allowing precise control over position and speed. With the ability to use potentiometers, servo systems can be created and controlled from any of RoboClaw's interface modes.

For greater control, built-in commands are available for controlling acceleration, deceleration, distance, speed, current sense, voltage and more. In addition, RC and analog modes can be configured by user defined settings to control acceleration and deceleration rates.

RoboClaw incorporates several protection features including temperature, current, over voltage and under voltage limits. The protection features are self monitoring and protect RoboClaw from damage in any operating condition. Several user definable settings such as maximum current limit, maximum and minimum battery voltages are provided for more refined control.

RoboClaw's regenerative capabilities will charge a supply battery during slow down or braking. It's advance circuitry can change direction during full throttle without damage! RoboClaw also incorporates a LiPo cutoff mode to prevent battery damage.

## Multimode Interface

RoboClaw's inputs are voltage protected and can handle up to 5VDC. The inputs only output a high of 3.3V. This allows RoboClaw to be interfaced to 5V or 3V logic easily with no translation circuits required. RoboClaw can be connected directly to a Raspberry Pi or Arduino. All of RoboClaw's inputs are internally pulled-up to prevent false triggers. Inputs can also be configured using the Ion Studio application.

### **User Regulated Power Output**

RoboClaw provides regulated power for user devices. A high efficiency switching regulator supplies 5VDC at up to 3Amps. This voltage can be used to power external sensors, encoders, MCU and other electronics. The regulated user power is automatically current limited and thermally protected.

### **Main Battery**

The peak operational input voltage depending on the model can be 34VDC, 60VDC or 80VDC. The models maximum input voltage can not be exceeded. Fully charged batteries maximum voltage must be taken into account when in used. RoboClaw is a regenerative motor controller. During regeneration, voltages can peak over the maximum rated voltage in which RoboClaw is designed to handle these over voltage spikes.

### **Logic Battery**

RoboClaw accepts a logic battery. The logic battery is also known as a backup battery. The user regulated power output (BEC) is by default powered from the main battery unless a logic battery is detected. The logic battery source is coupled to the main battery through a simple diode circuit. If the main battery voltage drops below the logic battery input level, the logic circuit and user regulated power output will be drawn from the logic battery.

### **Software**

RoboClaw can be easily configured using Ion Motion Control's software tools. The Windows based application enables users to quickly configure RoboClaw. The software can be used during run time to monitor and control several operational parameters. Ion studio is available from the Ionmc.com website. Its can be found in the downloads section of the site or listed under the production description.

### **User Manual**

This data sheet only covers model specific information and basic wiring. To properly setup and use RoboClaw refer to the RoboClaw User Manual available for download from <http://www.ionmc.com>.

### **Cooling**

RoboClaw will generate heat. The maximum current ratings can only be achieved and maintained with adequate heat dissipation. The motor controller should be mounted so that sufficient airflow is provided. Which will dissipate the heat away from the motor controller during operation. Some models of RoboClaw include built-in automatic cooling fan control which can be used to maintain continuous currents.

### **Emergency Stop**

The motor controller should be wired using an external contactor or relay to control the main power input. A second power source should be used to power the logic section in situations where the main power will be under heavy load. Voltage drops can occur from constant full load or high speed direction changes. Voltage drop can cause logic brown outs if only a main battery is used without a logic battery.

### **USB**

The motor controllers USB port should be used for configuration and debugging. The USB protocol is not designed for electrically noisy environments. The USB port will likely disconnect and not automatically recover during operation in electrically noisy environments. To recover from a dropped USB port, the motor controllers USB cable may require being unplugged and re-plugged in. The TTL serial control should be the preferred method of control in electrically noisy environments.

### **Firmware Updates**

Firmware updates will be made available to add new features or resolve any technical issue. Before using RoboClaw for the first time it is recommended to update to the latest firmware. Download and install Ion Studio. Refer to the RoboClaw User Manual for updating the RoboClaw firmware.

Hardware Overview:

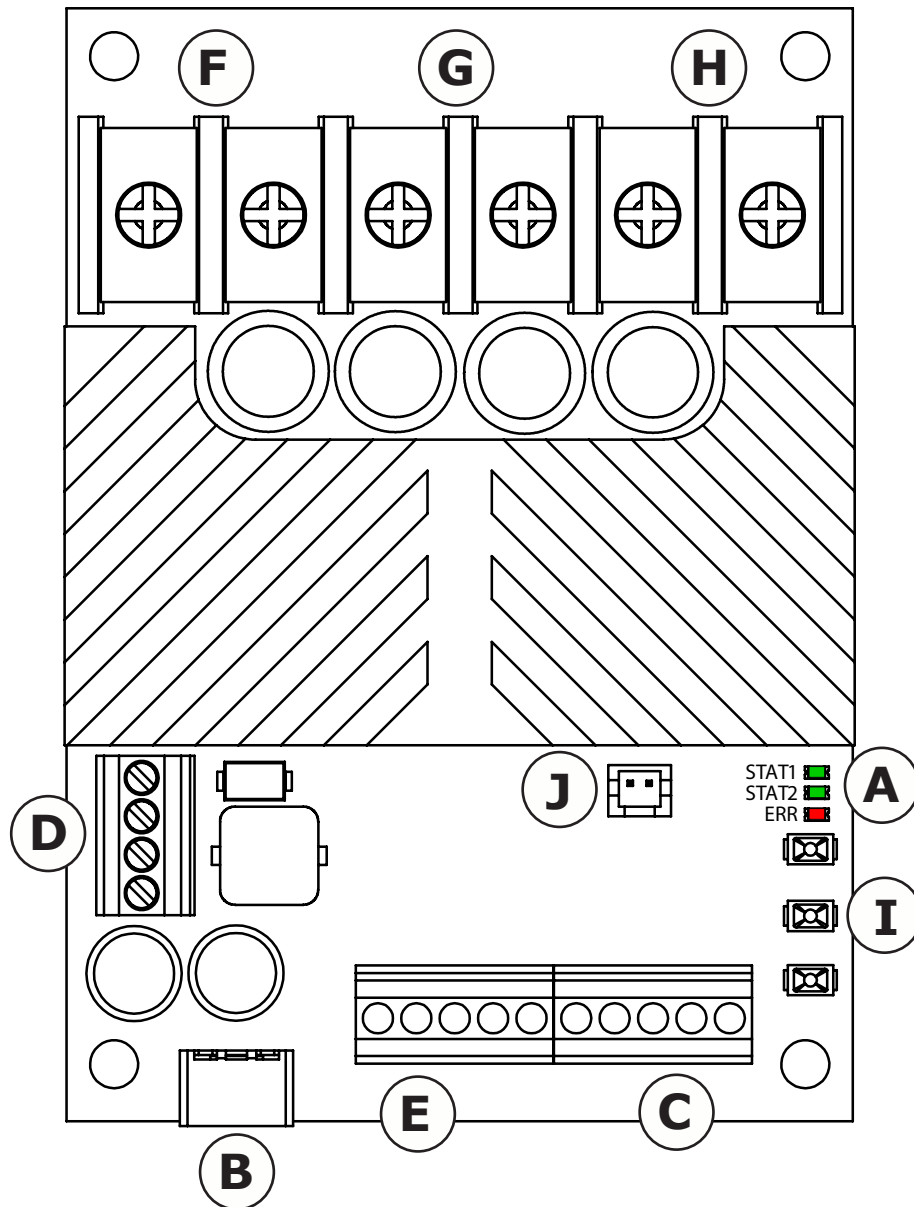

ID	Function	DESCRIPTION
A	Status LEDs	Provides RoboClaw status information.
B	USB Port	Communicate with RoboClaw via USB.
C	Control Inputs	S1,S2,S3,S4 and S5 control inputs.
D	Encoder Inputs	Dual encoder input and power pins.
E	Logic Battery	Logic battery jumper setup and logic battery power input.
F	Motor Channel 1	Motor driver output screw terminals for channel 1.
G	Main Battery	Main battery screw terminal input.
H	Motor Channel 2	Motor driver output screw terminals for channel 2.
I	Setup Buttons	Configure RoboClaw. Can bypass and use IonMotion PC setup utility.
J	Fan Control	Automatic fan control. 5VDC Fan. On at 45°C and off at 35°C

**Control Interface**

The RoboClaw use standard male pin headers with 0.100" (2.54mm) spacing. The pin headers are ideal for use with standard servo cables and other popular interface connectors. The table below list the pins and their respective functions. All pins are 5V tolerant and output 3.3V for compatibility with processor such as Raspberry Pi and Arduino. R/C pulse input, Analog and TTL can be generated from any microcontroller such as a Arduino or Raspberry Pi. The R/C Pulse input pins can also be driven by any standard R/C radio receiver. There are several user configurable options available. To configure RoboClaw, install Ion Studio and connect it to an available USB port.

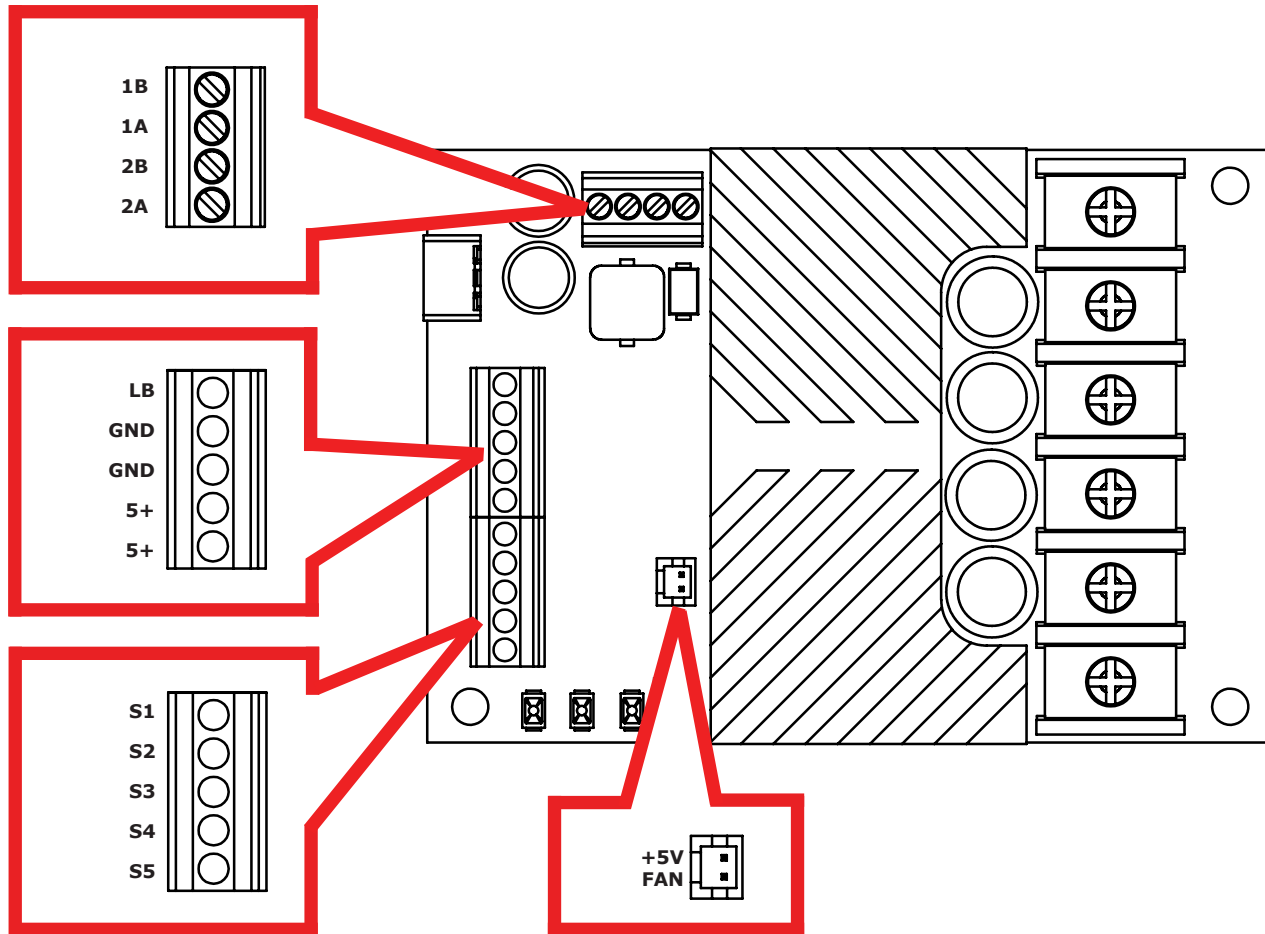

NAME	UART TTL	ANALOG	R/C PULSE	FLIP SWITCH	E-STOP	HOME	LIMIT	V-CLAMP	Encoder
S1	RX	Motor 1	Motor 1						
S2	TX	Motor 2	Motor 2						
S3				X	X			X	
S4					X	Motor 1	Motor 1	X	
S5					X	Motor 2	Motor 2	X	
1A									Motor 1
1B									Motor 1
2A									Motor 2
2B									Motor 2
+5V									
FAN									

### Logic Battery (LB IN)

The logic circuit of RoboClaw can be powered from a secondary battery wired to LB IN. A logic battery will prevent brownouts when the main battery is low or under heavy load. The positive (+) terminal is located at the board edge and ground (-) is the inside pin closest to the heatsink. Remove the LB-MB jumper if a secondary battery for logic will be used.

### BEC Source (LB-MB)

The RoboClaw logic requires 5VDC which is provided from the on board BEC circuit. The BEC power source input is set with the LB-MB jumper. Install a jumper on the 2 pins labeled LB-MB to use the main battery as the BEC power source. Remove the LB-MB jumper if using a separate logic battery. On models without this jumper the power source is selected automatically.



***Failure to remove LB-MB jumper when a logic battery is in use, will result in damage.***

### Encoder Power (+ / -)

The pins labeled + and - are the source power pins for encoders. The positive (+) is located at the board edge and supplies +5VDC. The ground (-) pin is near the heatsink. On RoboClaw screw terminal models all power must come from the single 5v screw terminal and the single GND screw terminal.

### Encoder Inputs (1A / 1B / 2A / 2B)

The encoders inputs are labeled EN1 and EN2. EN1 is for encoder 1 and EN2 is for encoder 2 which also correspond to motor channel 1 and motor channel 2. Quadrature encoder inputs are typically labeled 1A, 1B, 2A and 2B. Channel A of both EN1 and EN2 are located at the board edge on the pin header. Channel B pins are located near the heatsink on the pin header. Quadrature encoders are directional. When connecting encoders make sure the leading channel for the direction of rotation is connected to A. If one encoder is backwards to the other you will have one internal counter counting up and the other counting down. Use Ion Studio to determine the encoders direction to the motors rotation. Encoder channels A and B can be swapped in software using Ion Studio to avoid re-wiring the encoder or motor.

### Control Inputs (S1 / S2 / S3 / S4 / S5)

S1, S2, S3, S4 and S5 are configured for standard servo style headers I/O (except on ST models), +5V and GND. S1 and S2 are the control inputs for serial, analog and RC modes. S3 can be used as a flip switch input, when in RC or Analog modes. In serial mode S3, S4 and S5 can be used as emergency stops inputs or as voltage clamping control outputs. When configured as E-Stop inputs, they are active when pulled low. All I/O have internal pull-ups to prevent accidentally triggers when left floating. S4 and S5 can be configured as home switch and limit switch inputs. The pins closest to the board edge are the I/Os, center pin is the +5V and the inside pins are ground. Some RC receivers have their own supply and will conflict with the RoboClaw's 5v logic supply. It may be necessary to remove the +5V pin from the RC receivers cable in those situations.

### Cooling Fan Control

The cooling fan control will automatically turn on and off a fan based on RoboClaws temperature. The fan will turn on when the board temperature reaches 45°C and will automatically turn off when the board temperature falls below 35°C. The fan control circuit can power a 5VDC fan at up to 230mA. There is a wide range of fans that can be used. The CFM rating of the fan will determine how effective the fan is at cooling. A tested fan is available from DigiKey under part number: 259-1577-ND. However any fan can be used provide it meets the electrical specifications above. The 2 pin on board mating connector is available from DigiKey under part number: H2179-ND. Which requires two pins listed under part number: H9991CT-ND.

### Main Battery Screw Terminals

The main power input can be from 6VDC to 34VDC on a standard RoboClaw and 10.5VDC to 60VDC or 80VDC on an HV (High Voltage) RoboClaw. The connections are marked + and - on the main screw terminal. The plus (+) symbol marks the positive terminal and the negative (-) marks the negative terminal. The main battery wires should be as short as possible.



***Do not reverse main battery wires or damage will occur.***

### Disconnect

The main battery should include a quick disconnect in case of a run away situation and power needs to be cut. The switch must be rated to handle the maximum current and voltage from the battery. Total current will vary depending on the type of motors used. A common solution would be an inexpensive contactor which can be source from sites like Ebay. A power diode rated for the maximum current the battery will deliver should be placed across the switch/contacter to provide a path back to the battery when disconnected while the motors are spinning. The diode will provide a path back to the battery for regenerative power even if the switch is opened.

### Motor Screw Terminals

The motor screw terminals are marked with M1A / M1B for channel 1 and M2A / M2B for channel 2. For a typical differential drive robot the wiring of one motor should be reversed from the other. The motor and battery wires should be as short as possible. Long wires can increase the inductance and therefore increase potentially harmful voltage spikes.

## **Control Modes**

RoboClaw has 4 main functional control modes explained below. Each mode has several configuration options. The modes can be configured using Ion Studio or the built-in buttons. Refer to the RoboClaw User Manual for installation and setup instructions.

## **RC**

Using RC mode RoboClaw can be controlled from any hobby RC radio system. RC input mode also allows low powered microcontrollers such as a Basic Stamp to control RoboClaw. Servo pulse inputs are used to control the direction and speed. Very similar to how a regular servo is controlled. RC mode can be used with encoders. Refer to the RoboClaw user manual for setup instructions.

## **Analog**

Analog mode uses an analog signal from 0V to 2V to control the speed and direction of each motor. RoboClaw can be controlled using a potentiometer or filtered PWM from a microcontroller. Analog mode is ideal for interfacing RoboClaw with joystick positioning systems or other non microcontroller interfacing hardware. Analog mode can use encoders if properly setup(See Encoder section).

## **Simple Serial**

In simple serial mode RoboClaw expects TTL level RS-232 serial data to control direction and speed of each motor. Simple serial is typically used to control RoboClaw from a microcontroller or PC. If using a PC, a MAX232 or an equivalent level converter circuit must be used since RoboClaw only works with TTL level inputs. Simple serial includes a slave select mode which allows multiple RoboClaws to be controlled from a signal RS-232 port (PC or microcontroller). Simple serial is a one way format, RoboClaw can only receive data. Encoders are not supported in Simple Serial mode.

## **Packet Serial**

In packet serial mode RoboClaw expects TTL level RS-232 serial data to control direction and speed of each motor. Packet serial is typically used to control RoboClaw from a microcontroller or PC. If using a PC a MAX232 or an equivalent level converter circuit must be used since RoboClaw only works with TTL level input. In packet serial mode each RoboClaw is assigned a unique address. There are 8 addresses available. This means up to 8 RoboClaws can be on the same serial port. Encoders are support in Packet Serial mode(See Encoder section).

## **USB Control**

USB can be used in any mode. When RoboClaw is in packet serial mode and another device, such as an Arduino, is connected commands from the USB and Arduino will be executed and can potential over ride one another. However if RoboClaw is not in packet serial mode, motor movement commands will not function. USB packet serial commands can then only be used to read status information and set configuration settings.



**Wiring Basics**

There are several wiring configurations for RoboClaw. Each configuration will have unique wiring requirements to ensure safe and reliable operation. The diagram below illustrates a very basic wiring configuration used in a small motor system where safety concerns are minimal. This is the most basic wiring configuration possible. All uses of RoboClaw should include some kind of main battery shut off switch, even when safety concerns are minimal. Never underestimate a system with movement when an uncontrolled situation arises.

In addition, RoboClaw is a regenerative motor controller. If the motors are moved when the system is off, it could cause potential erratic behavior due to the regenerative voltages powering the system. The regenerative voltages can will cause problems if a power supply is used to power RoboClaw. A voltage clamping circuit is required to dump the excessive voltages. See the RoboClaw user manual for voltage clamping setup and wiring diagrams.

**R/C Mode**

The below wiring diagram is very basic and for use with R/C mode. R/C mode can be used when pairing RoboClaw with a standard R/C receiver. R/C mode can also be used with a microcontroller and using servo pulses to control RoboClaw. The RoboClaw supplies power to the R/C system. If the R/C receiver used, has its own power the 5V pin on the 3 pin header must be remove otherwise it will interfere with RoboClaw's BEC.

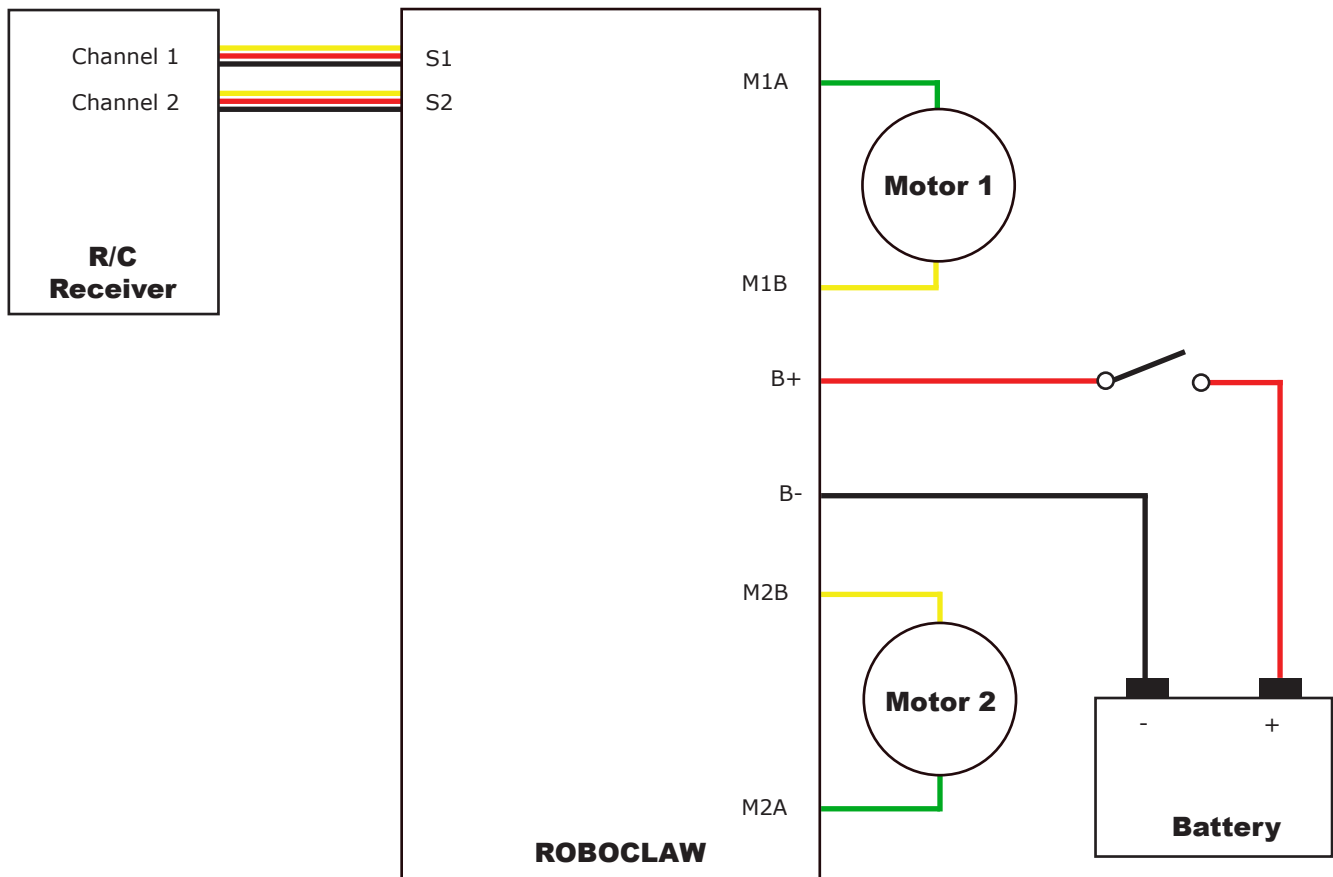

**Wiring Safety**

In all system with movement, safety is a concern. The wiring diagram below illustrates a properly wired system for safety. An external main power cut off is required for safety. When the RoboClaw is switched off or the fuse is blown, a high current diode (D1) is required to create a return path to the battery for any regenerative voltages. The use of a pre-charge resistor (R1) is required to avoid high inrush currents and arcing. A pre-charge resistor (R1) should be 1K, 1/2Watt for a 60VDC motor controller which will give a pre-charge time of about 15 seconds. A lower resistances can be used with lower voltages to decrease the pre-charge time.

**Closed Loop Mode**

A wide range of sensors are supported for closed loop operation. RoboClaw supports dual quadrature encoders (up to 19.6 million QPPS), absolute encoders, potentiometers and hall effect sensors. The wiring diagram below is an example of closed loop mode using quadrature encoders. Quadrature encoders are directional. RoboClaw’s internal counters will increment for clockwise rotation (CW) and decrement for counter clockwise rotation (CCW). When wiring encoders A and B channels it is important they are wired to match the direction of the motor. If the encoder is wired in reverse it can cause a run away condition. All motor and encoder combinations will need to be tuned (see the RoboClaw user manual).

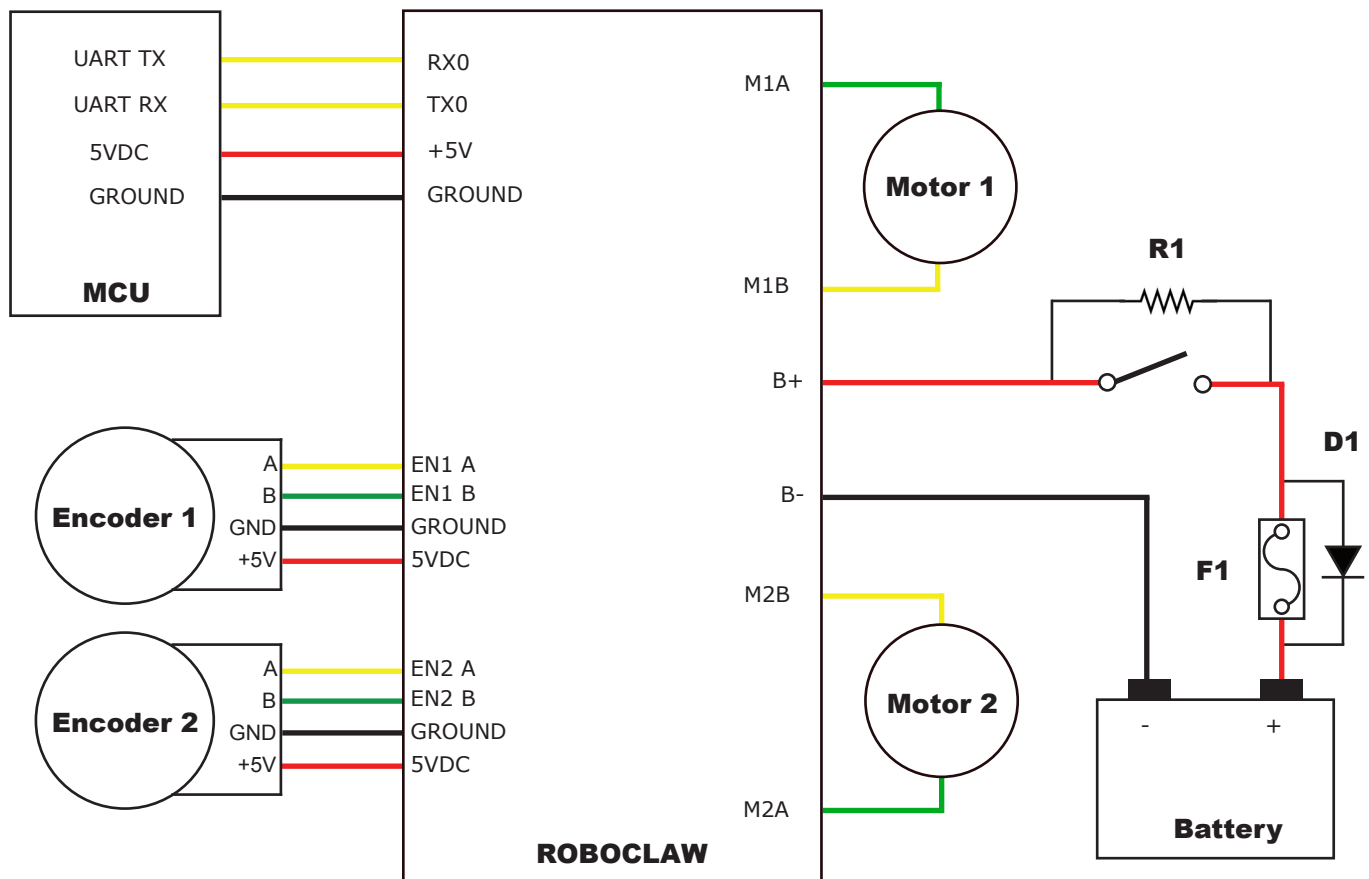

**Logic Battery**

An optional logic battery is supported. Under heavy loads the main power can suffer voltage drops, causing potential logic brown outs which may result in uncontrolled behavior. A separate power source for the motor controllers logic circuits, can remedy potential problems from main power voltage drops. The logic battery maximum input voltage is 34VDC with a minimum input voltage of 6VDC. The 5V regulated user output is supplied by the secondary logic battery if supplied. The mAh of the logic battery should be determined based on the load of attached devices powered by the regulated 5V user output.

**Logic Battery Jumper**

The configuration below utilizes a logic battery. Some models of RoboClaw have a logic battery jumper. On models where the LB-MB header is present the jumper must be removed when using a separate logic battery. If the header for LB-MB is not present, then the RoboClaw will automatically set the logic battery power source.

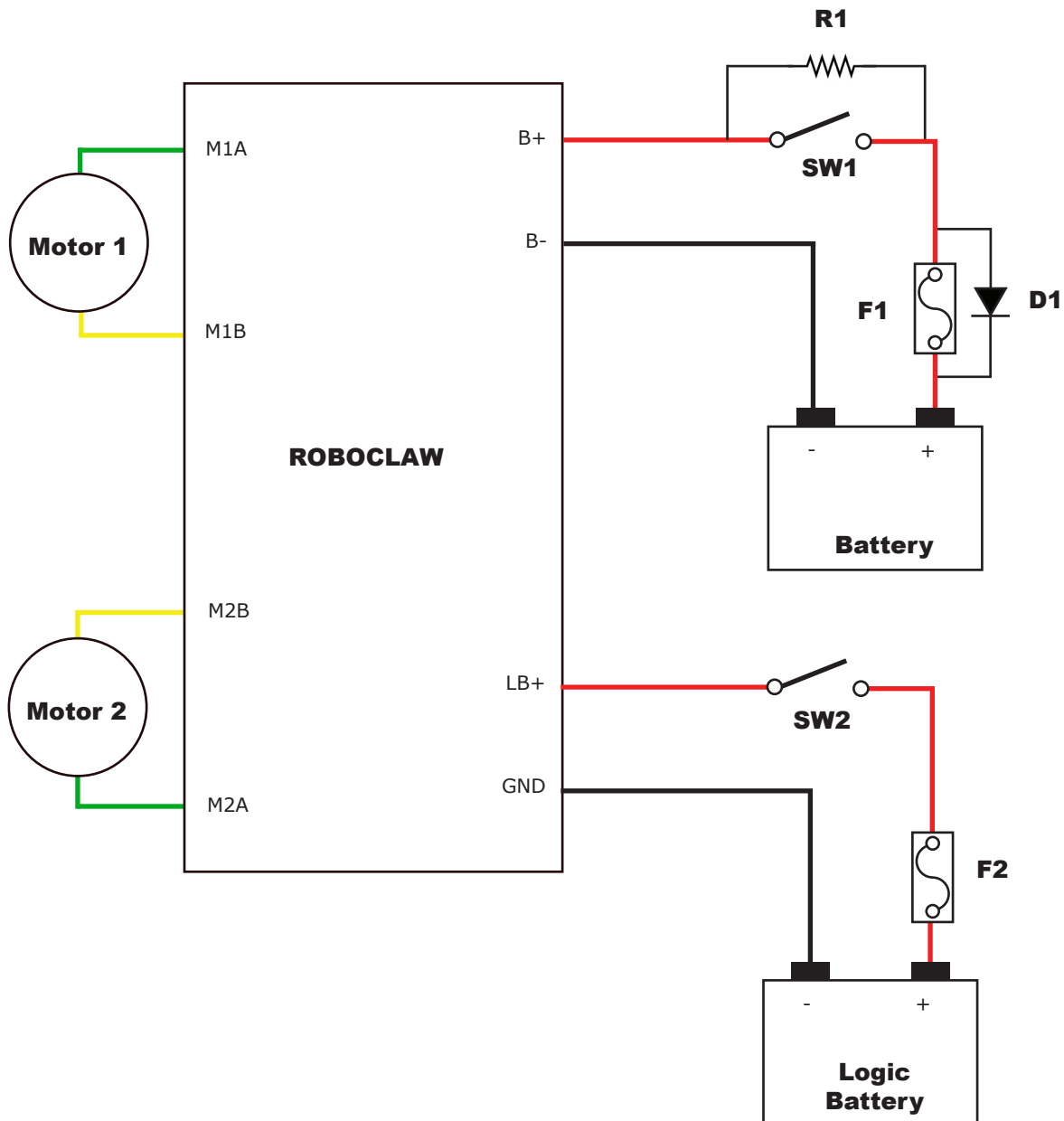

**Bridging Channels**

RoboClaws dual channels can be bridge to run as one channel, effectively doubling its current capability for one motor. Damage will result if RoboClaw is not set to bridged channel mode before wiring. Download and install Ion Studio. Connect the motor controller to the computer using an available USB port. Run Ion Studio and in general settings check the option to combine channels. Then click "Save Settings" in the device menu. When operating in bridged channel mode the total peak current output is combined from both channels. The peak current run time is dependant on heat build up. Adequate cooling must be maintained. For more information see the RoboClaw user manual.

**Bridged Channel Wiring**

When bridged channel mode is active the internal driver scheme for the output stage is modified. The output leads must be wired correctly or damage will result. One side of the motor is connected to M1A and M2B. The other side of the motor is then connected to M1B and to M2A.

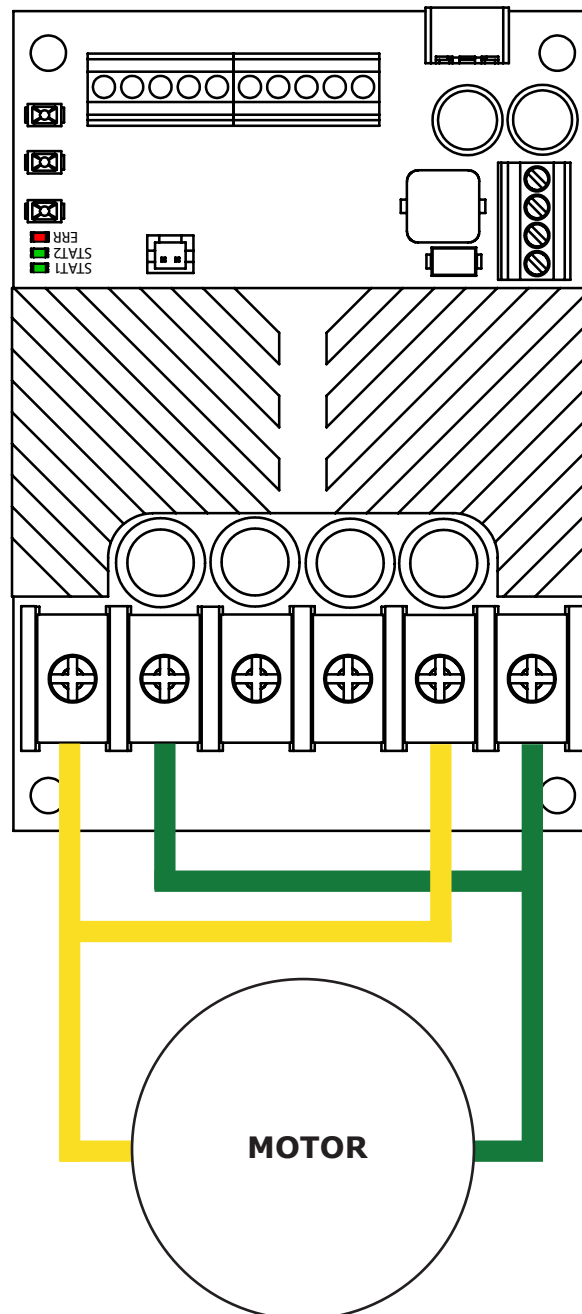

Mechanical Specifications

Characteristic	Model	Min	Typ	Max	Rating
Weight	ST 2X45A		2.2 (62)		Oz (g)

Dimensions

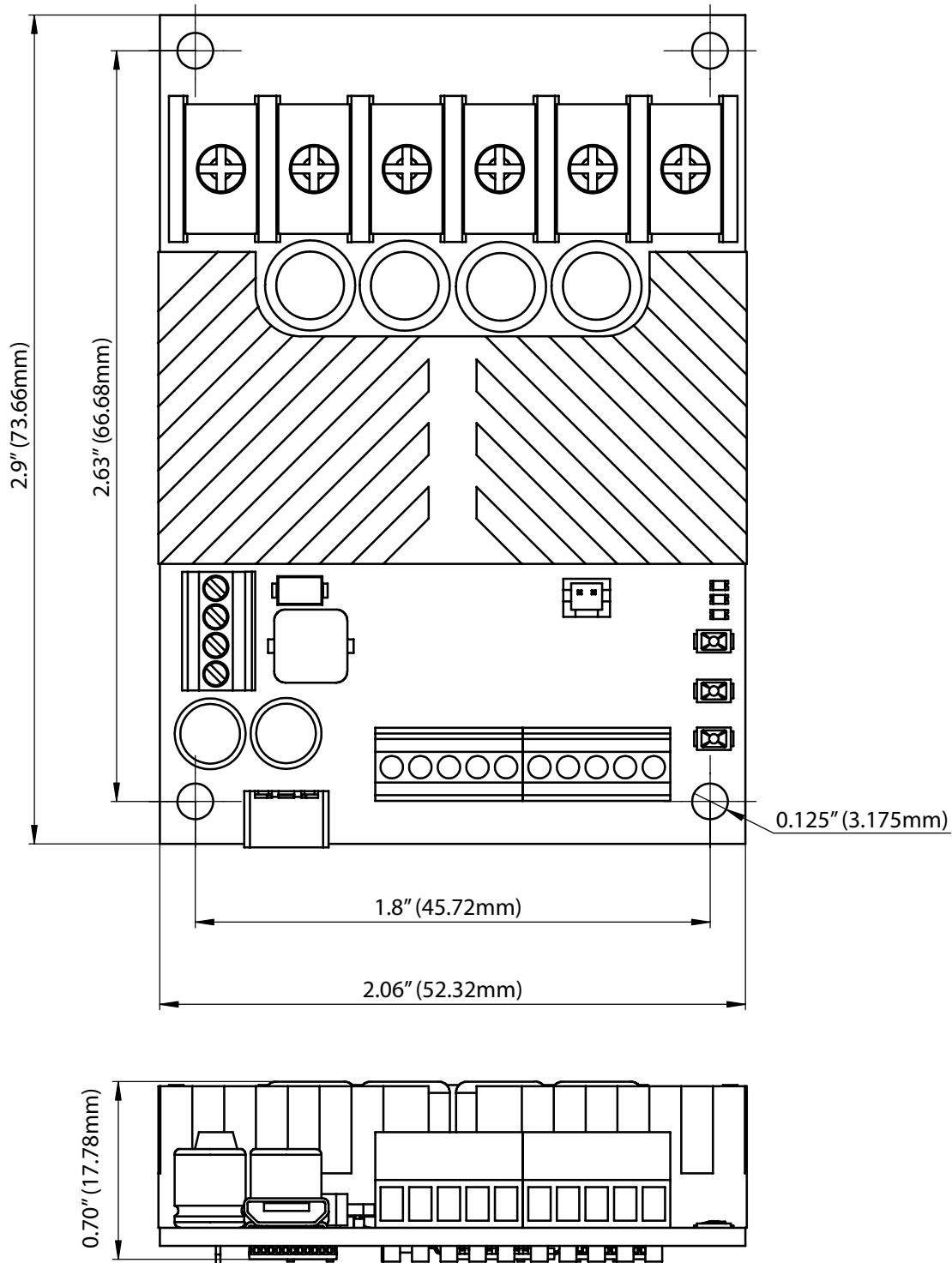

## Electrical Specifications

Characteristic	Min	Typ	Max	Rating
Main Battery	6		34	VDC
Logic Battery	6	12	34	VDC
Maximum External Current Draw (BEC)			3	A
Motor Current Per Channel		45 <sup>(2)</sup>	60 <sup>(1,2)</sup>	A
Motor Current Bridged		90 <sup>(2)</sup>	120 <sup>(1,2)</sup>	
On Resistance		1.9		mOhm
Logic Circuit Current Draw		90mA		mA
Input Impedance		100		Ω
Input	0		5	VDC
Input Low	-0.3		0.8	VDC
Input High	2		5	VDC
I/O Output Voltage	0		3.3	VDC
Digital and Analog Input Voltage			5	VDC
Analog Useful Range	0		2	VDC
Analog Resolution		1		mV
Pulse Width	1		2	mS
Encoder Counters		32		Bits
Encoder Frequency			19.66	Mhz
RS232 Baud Rate (Note 3)			460,800	Bits/s
RS232 Time Out (Note 3)	10			ms
Temperature Range	-40	40	100	°C
Temperature Protection Range	85		100	°C
Humidity Range			100 (4)	%

**Notes:**

1. Peak current is automatically reduced to the typical current limit as temperature approaches 85°C.
2. Current is limited by maximum temperature. Starting at 85°C, the current limit is reduced on a slope with a maximum temperature of 100°C, which will reduce the current to 0 amps. Current ratings are based on ambient temperature of 25°C.
3. RS232 format is 8Bit, No Parity and 1 Stop bit.
4. Condensing humidity will damage the motor controller.

## Warranty

Ion Motion Control warrants its products against defects in material and workmanship for a period of 1 year. If a defect is discovered, Ion Motion Control will, at our discretion, repair, replace, or refund the purchase price of the product in question. Contact us at [sales@ionmc.com](mailto:sales@ionmc.com). No returns will be accepted without the proper authorization.

## Copyrights and Trademarks

Copyright© 2015 by Ion Motion Control, Inc. All rights reserved. All referenced trademarks mentioned are registered trademarks of their respective holders.

## Disclaimer

Ion Motion Control cannot be held responsible for any incidental or consequential damages resulting from use of products manufactured or sold by Ion Motion Control or its distributors. No products from Ion Motion Control should be used in any medical devices and/or medical situations. No product should be used in a life support situation.

## Contacts

Email: [sales@ionmc.com](mailto:sales@ionmc.com)

Tech support: [support@ionmc.com](mailto:support@ionmc.com)

Web: <http://www.ionmc.com>

## Discussion List

A web based discussion board is maintained at <http://www.ionmc.com>

## Technical Support

Technical support is available by sending an email to [support@ionmc.com](mailto:support@ionmc.com), by opening a support ticket on the Ion Motion Control website or by calling 800-535-9161 during normal operating hours. All email will be answered within 48 hours.