

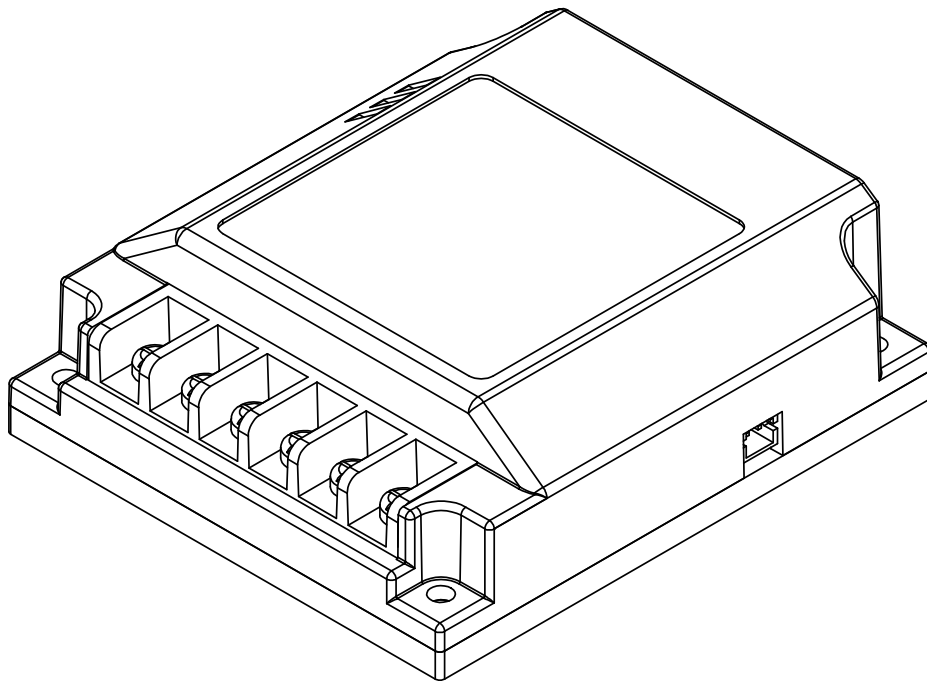

MOTION CONTROL



**MCP230A Dual Channel Programmable
Brushed DC Motor Controller**

Feature Overview:

- 30 Amps per channel continuous for two brushed DC motors
- 60 Amps in bridged channel mode for one brushed DC motor
- Dual quadrature encoder inputs with hardware 32-Bit counters
- Programmable with built-in user scripting language
- Minimum of 100,000 instructions per second execution speed
- 128Kb Flash available for user scripting programs
- 16Kb Ram allocated for user scripting programs
- 1kb Eeprom for storage by user scripting programs
- USB, RS232, TTL, R/C, PWM and Analog control modes
- Automatic switch control methods with user defined priority settings
- Mixed Control Inputs
- Data Logging
- Diagnostic LEDs for easy in field diagnostics
- Field Firmware Updates
- OpenCAN master or slave support
- I2C Interface for use with sensors such as gyros, accelerometers, temperature and displays
- Up to 6 Analog inputs for control, encoder feedback or as user script controlled inputs
- Up to 6 PWM inputs for control, encoder feedback or as user script controlled inputs
- Up to 6 Digital inputs for limit switches, emergency stops, homing or as user script controlled inputs
- 2 General purpose 40V, 3Amp user controlled outputs for driving relays, brakes or contactors
- User programmable input triggers with minimum and maximum range settings
- Regulated 5VDC, 500mA output for powering external devices such as sensors or controllers like Arduino, Raspberry Pi
- Up to 80VDC versions available
- Fully enclosed for protection
- Conduction plate and top side heat management for high performance cooling
- 3.3v Compliant outputs for safe interfacing with controllers such as Raspberry Pi
- 15v Tolerant inputs for interfacing to industrial devices such as PLCs
- Overvoltage and under voltage protection monitoring
- Programmable current limiting
- Auto tune PID feature for fast encoder motor setup
- PC utility included for fast setup and tuning

Device Overview

The MCP series motor controller is a high power, high performance rugged motor controller built to withstand the most demanding applications. It incorporates a built-in scripting language with advanced motion control. At the heart is a 32Bit high performance Cortex M4 processor with DSP and FPU. The user programmable feature allows the MCP to be customized for any application. It can interface with several communication standards in addition to including several user configurable I/O. The MCP can be used as a standalone controller without the need for an additional processor therefore reducing overall design cost and system complexity.

At the heart of the MCP motor controller is a high performance motion control intelligence which achieves high precision control and optimum motor performance in open or closed loop modes. Closed loop mode supports dual quadrature encoders with up to 21 million PPS. Closed loop mode creates absolute control over speed, velocity and direction regardless of loading changes. In addition, a wide range of sensor inputs including potentiometers and absolute encoders are supported.

Multimode Interface

The MCP supports several types of control input. USB, R/C Pulse, Analog, TTL, RS232 and CAN are supported. Control can be setup to auto switch from one interface to another. The MCP can be configured as a master or slave in a CAN network. In addition several user controllable I/O are available for setting up limit switches, sensors, E-stops and more. The MCP includes 2 user controllable general purpose 40V at 3Amp I/O for controlling brakes, contactors and other high load devices.

Protection

The MCP utilizes high precision temperature, current and voltage sensing to monitor conditions and ensure safe and reliable operations. The peak operational voltage depending on model can be up to 80VDC. MCP is a regenerative motor controller. During regeneration, voltages can peak over 80VDC. MCP is designed to handle well over 100VDC voltage spikes and is not rated to its absolute maximum operating specifications which provides a safe and reliable operating margin.

Software

IonMotion is a free PC utility configuration tool used to setup, configure and monitor the MCP. The software can be used during run time to monitor and control several operational parameters. IonMotion is also the interface for customizing the built-in motion control language.

Hardware Overview:

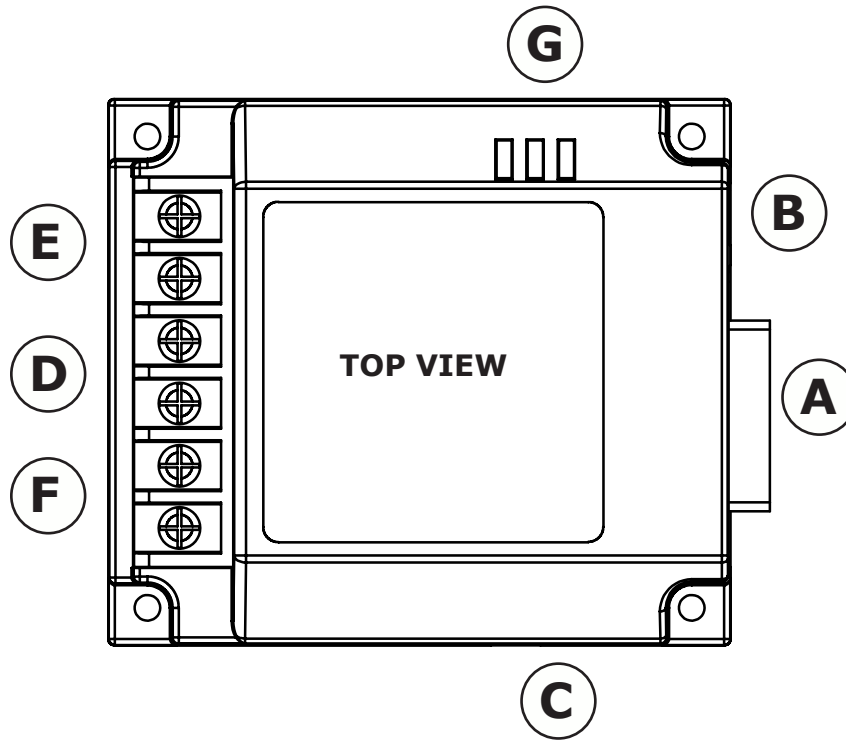

FRONT VIEW

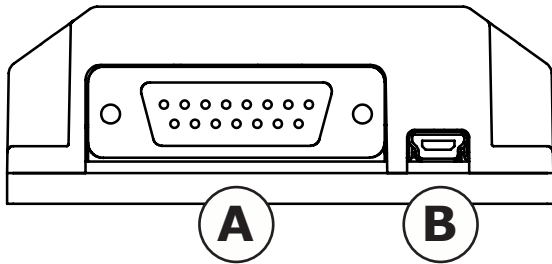

SIDE VIEW

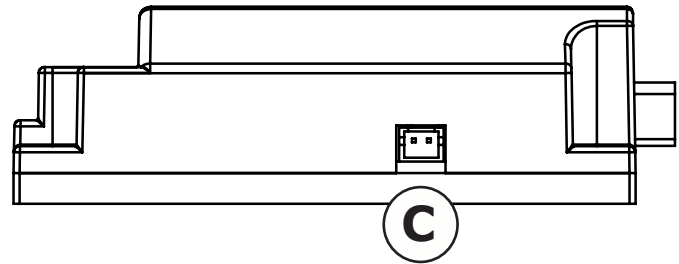

Label	Function
A	DB15 Female Connector.
B	Micro USB Port.
C	Logic Battery Connector.
D	Main Battery Input.
E	Motor Channel 1
F	Motor Channel 2.
G	Status LEDs.

Interface

The MCP230 uses a DB15 female connector and 2 pin JST connector. The following tables list the pins and their respective functions. All digital input are 15V tolerant. Digital output pins can drive up to 3Amps at 40VDC. The CAN interface and RS232 pins are duplexed. When a duplex function is used the other is set to a high Z state. R/C pulse input, Analog, TTL and PWM can be generated from any microcontroller such as a Arduino or Raspberry Pi. The R/C Pulse in pins can be driven by any standard R/C radio receiver. There are several user configurable options depending on the device used to control the MCP. The IonMotion App is recommended to configure the MCP from the USB port.

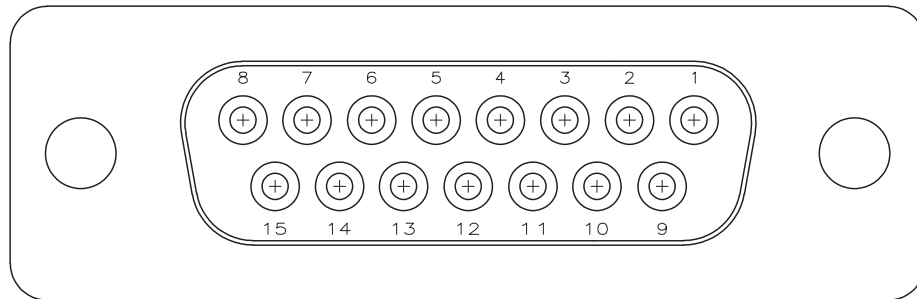

Pin	PWR	DIN	DOUT	ANALOG	PULSE	ENCODER	UART TTL	UART RS232	CAN	I2C
1			DOUT1							
9			DOUT2							
2	GND									
10	GND									
3	+5V									
11							TX1			SCL
4							RX1			SDA
12								RX0	CANL	
5								TX0	CANH	
13		DIN1		AN1	P1	HALL3	TX3			
6		DIN2		AN2	P2		RX3			
14		DIN3		AN3	P3	ENC1A / HALL1	TX2			
7		DIN4		AN4	P4	ENC2A				
15		DIN5		AN5	P5	ENC1B / HALL2	RX2			
8		DIN6		AN6	P6	ENC2B				

Notes:

1. Digital input pins are 15V tolerant.
2. Digital output pins can drive up to 3Amp at 40V. DOUT are low side driving pins.
3. Analog pins are 0V to 5.1V range.
4. I2C pins are 5V tolerant inputs with 3.3V compliant output.
5. Pulse inputs have a resolution of 12ns.

Logic Battery

The MCP supports an optional logic battery. Under heavy loads the main power can dip potentially causing brown outs. The separate logic battery will alleviate this problem. In addition a logic battery should be utilized to avoid uncontrolled behavior when the main battery power becomes low. The logic battery maximum input voltage is 12VDC with a minimum input voltage of 6VDC. The mAh of the battery should be determined based on the loading conditions. The BEC is supplied by the logic battery when it is attached. Any additional electronics attached to the MCP and powered from the MCP will need to be accounted for when determining the logic battery size.

Logic Battery Wiring

The MCP comes with a small 2pin JST connector for the logic battery. The MCP is shipped with a wired pig tail mating connector. The mating connector can also be sourced from DigiKey 455-1165-ND. The 2 pins are ground and power as shown below.

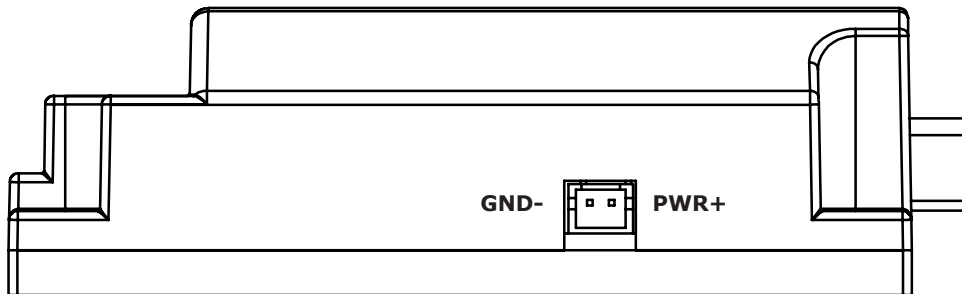

Important Notices

The following information is required for safe and reliable operation. It is up to the user to ensure the following criteria is met. Several external factors can influence how the MCP operates. Following basic safety procedures can prevent dangerous situations.

Warnings

The following guidelines should be followed when using the MCP or damage will occur. There are several factors that will affect the operation of the MCP.

1. Battery wire should be no longer than 20 inches in length.
2. Motor wire should be no longer than 20 inches in length.
3. DO NOT overload the BEC. Logic power is drawn from the same source and brownouts can occur.
4. DO NOT reverse the battery polarity. Damage will result.
5. ALWAYS Incorporate an emergency main battery cut off switch.
6. Cut off should always be on the positive (+) of power to prevent ground loops.
7. Power diode, fuse and pre charge resistor should be added to all power switch circuits.
8. DO NOT get the MCP wet and avoid high moisture environments without proper moisture control.

Mounting

The MCP will generate heat. The controller should be mounted to a metal surface that will conduct the heat away from the MCP during operation. The maximum amperage ratings can only be achieved and maintained with adequate heat dissipation.

Emergency Stop

MCP should be wired using an external contactor or relay to ultimately control the main power input. A second power source should be used to power the logic section in situations where the main power will be under heavy load. Voltage level drops can occur from constant full load or full speed direction changes and can potential cause logic brown outs.

USB

The MCP USB port can be used for configuration and debugging. The USB protocol is not meant for electrically noisy environments. The USB port can potentially drop out during operation and may not recover without unplugging and plugging in the MCP. In high electrical noise environment RS232 should be used.

CAN Bus

The MCP can interface to a CAN bus using CANOpen protocol. The MCP supports the DS402 profile for motion control devices. The MCP can be a master or slave devices on the bus. CAN is available when the MCP is plugged into the USB. The MCP can be used as a master interface to control other MCPs over the a CAN bus.

I2C

The I2C buss can be used to communicate to any compatible I2C device. The I2C device can be controlled by a user program. The MCP can be easily interfaced to devices such as Gyro and Accelerometers for standalone applications.

Firmware Updates

From time to time new firmware updates will be available to add new features or resolve an issue. It is recommended to update to the latest firmware during development. Firmware updates are handled by the IonMotion PC utility. IonMotion is free to download from Ionmc.com. Once IonMotion is installed, connect the motor controller to your computer running Windows 7 or newer. Once IonMotion is launched it will detect the attached motor controller and attempt to first download the latest firmware from Ionmc.com before updating.

Wiring Basics

The MCP must be wired correctly to ensure safe and reliable operation. The diagram below illustrates a basic configurations for wiring. An external main power cut off solution should be incorporated for safety. Power generation will occur if the motors are moved when the system is off. Use a high current diode to create a return path to ground when the unit is switched off. Add a pre charge resistor to avoid high inrush currents. Pre charge resistor should be 1K, 2Watt for 80VDC models. A lower resistance can be used with lower voltages to decrease the pre-charge time.

Wiring Closed Loop Mode

The MCP supports a wide range of sensors for closed loop function. Absolute and quadrature encoders are supported along with potentiometers and hall effect sensor.

The below illustration shows the basic wiring required for closed loop mode using quadrature encoders. Quadrature encoders are directional. The internal MCP counter to increment in one direction and decrement in the opposite direction. When wiring encoders it is important they are wired to match the direction of the motor. If the encoder is wired in reverse it can cause a run away condition.

Wiring Diagrams

The MCP has several different configurations depending on the type of input or output being used. See the MCP manual for additional diagrams examples.

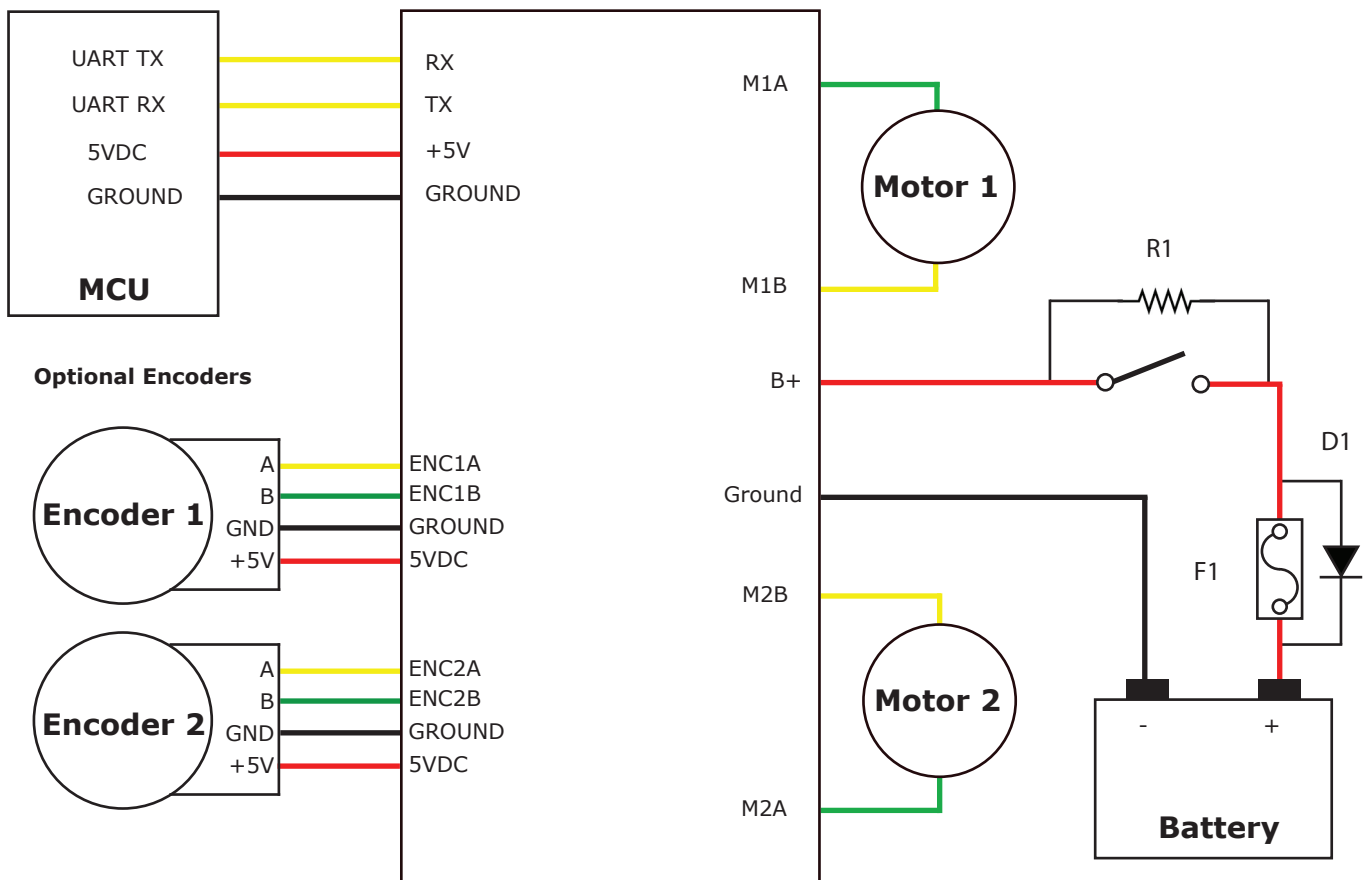

Status and Error LEDs

The MCP has three LEDs. Two status LEDs named STAT1 and STAT2 and an error LED named ERR. When MCP is first powered up all 3 LEDs should flash briefly to indicate all LEDs are functional. The LEDs will behave differently depending on the mode. During normal operation the status 1 LED will remain on continuously or blink when data is received in RC Mode or Serial Modes. The status 2 LED will light when either drive stage is active.

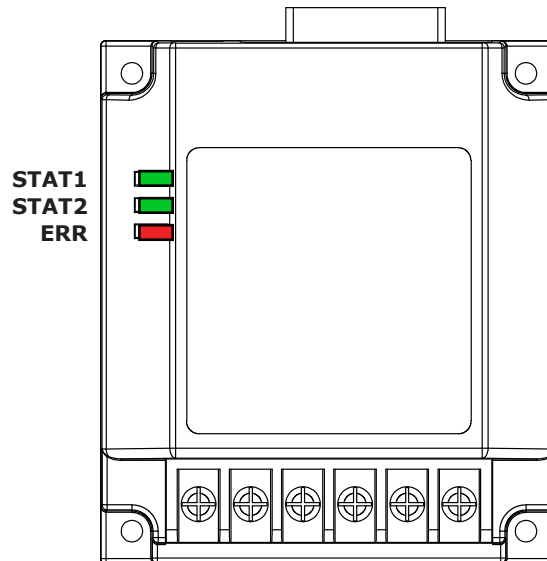

Error and Warning States

When an error occurs both motor channel outputs will be disabled and the MCP will stop any further actions until the unit is reset, or in the case of non-latching E-Stops, the error state is cleared. When warnings occur both motor channel outputs will be controlled automatically depending on the warning condition(s).

Condition	Type	LED Status	Description
E-Stop	Error	All three LEDs lit.	Motors are stopped by braking.
Over 85c Temperature	Warning	Error LED lit while condition is active.	Motor current limit is recalculated based on temperature.
Over 100c Temperature	Error	Error LED blinks once with short delay. Other LEDs off.	Motors freewheel while condition exist.
Over Current	Warning	Error LED lit while condition is active.	Motor power is automatically limited.
Logic Battery High	Error	Error LED blinking three times.	Motors freewheel until MCP is reset.
Logic Battery Low	Error	Error LED blinking four times.	Motors freewheel until MCP is reset.
Main Battery High	Error	Error LED blinking five times.	Motors are stopped by braking until MCP is reset.
Main Battery High	Warning	Error LED lit while condition is active.	Motors are stopped by braking while condition exist.
Main Battery Low	Warning	Error LED lit while condition is active.	Motors freewheel while condition exist.
M1 or M2 Home	Warning	Error LED lit while condition is active.	Motor is stopped and encoder is reset to 0

Firmware Update LED State

If all three LEDs begin to cycle on and off after powering on, the MCP has successfully been set to receive new firmware. Use IonMotion on a Windows PC to install the new firmware to clear this state.

Automatic Battery Detection on Startup

If the automatic battery detection mode is enabled the Stat2 LED will blink to indicate the detected battery type. Each blink indicates the number of LIPO cells detected. If automatic detection is used the number of cells detected should be confirmed on power up before running the unit.



Undercharged or overcharged batteries can cause invalid auto detection.

Motion Control Language

The MCP motor controller can be customized using a built in programming language. The programming language is modeled after BASIC. The MCP motor controller can operate in standalone mode without additional external control. Several user I/O and operational parameters are directly accessible from user programs. The MCP includes IonMotion which is a free PC utility to create and download user programs to the motor controller.

Programming Specifications

Characteristic	Model	Min	Typ	Max	Rating
User Program Memory	All		128		KBytes
User Variable Memory	All		16		KBytes
User Program Execution Speed	All		100,000		Lines/s
Analog to Digital Resolution	All			12	Bits
System Clock Resolution	All			32	Bits
Microsecond Clock Resolution	All			32	Bits
Millisecond Clock Resolution	All			32	Bits
Uart Buffer	All			256	Bytes
Subroutine Nesting				256	Levels

Bridged Channel Mode

The MCPs dual channels can be bridge to run as one channel effectively doubling its current capability for one motor. Damage will result if the MCP is not set to bridge channel mode before wiring. Download and install IonMotion PC utility. Connect the MCP to the computer using an available USB port. Run IonMotion and in general settings check the option to combine channels. When operating in bridged channel mode the total peak current output is 60 amps. Peak current is directly affected by heat build up. If adequate cooling is maintained, peak currents can be sustained indefinitely.

Bridged Channel Wiring

When bridged channel mode is active the internal driver scheme for the output stage is modified. The output leads must be wired correctly or damage will result. The motor output wire M1A is bridged to M1B to create one side. Then M2A is bridged to M2B to form the other side.

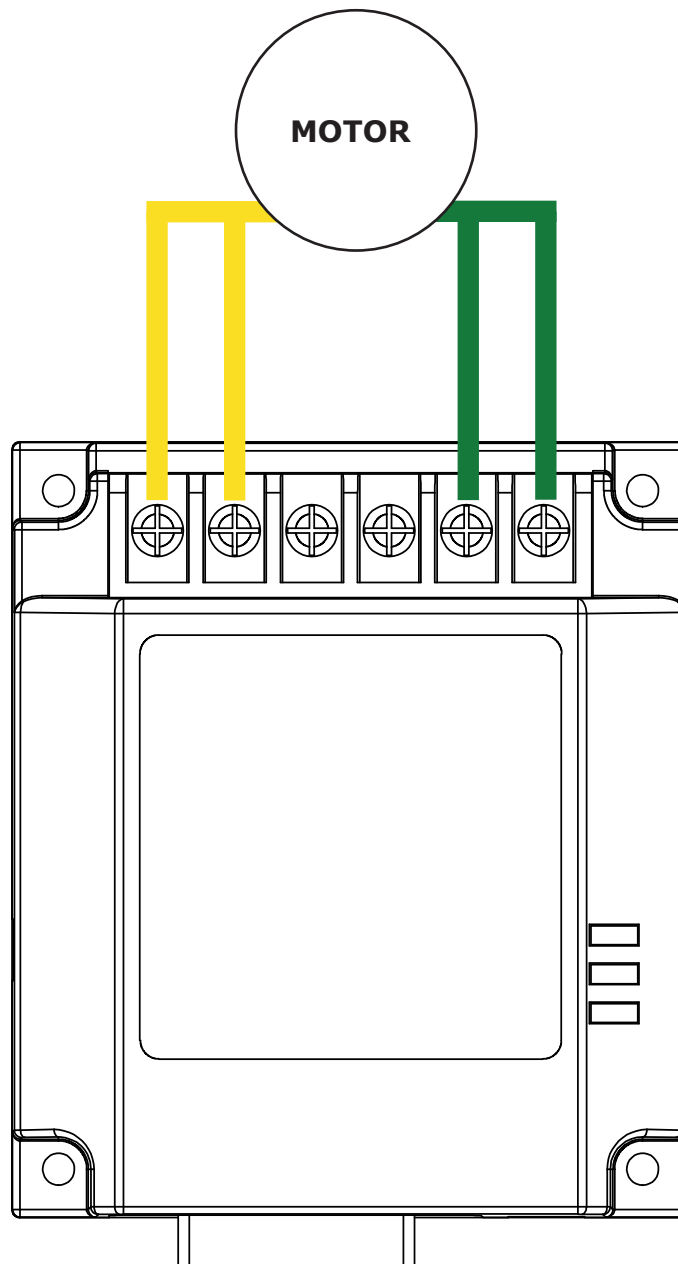

Mechanical Specifications

Characteristic	Model	Min	Typ	Max	Rating
Weight	MCP230		5 (141)		Oz (g)

Mechanical Dimensions

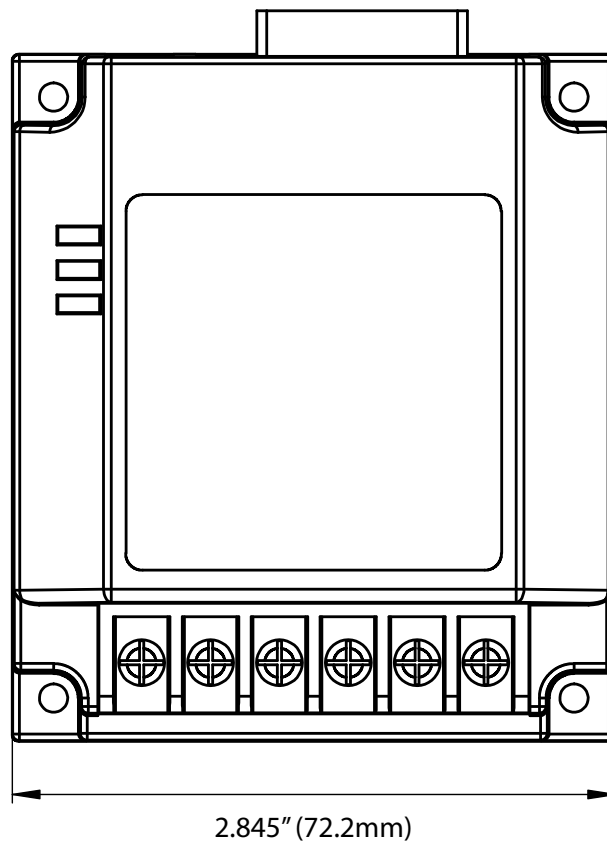
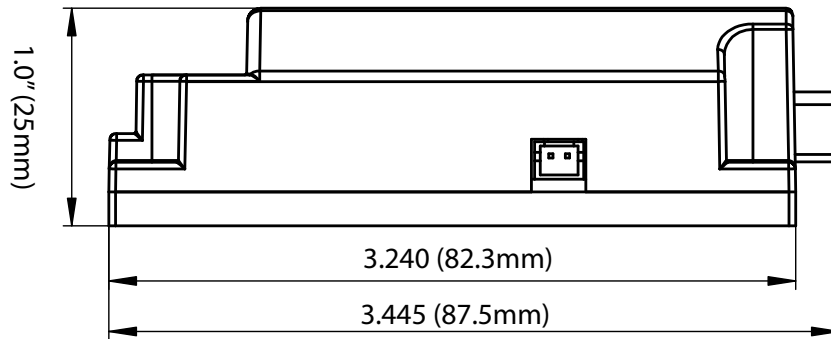

MCP230 Specifications

Characteristic	Min	Typ	Max	Rating
Logic Battery	6	12	34	VDC
Main Battery	10		60	VDC
Maximum External Current Draw (BEC)			300	mA
Motor Current Per Channel			30	A
Motor Current Bridged Channel Mode			60	A
Logic Circuit Current Draw		90mA		mA
Input Impedance		1.2		K Ω
I2C Input Impedance		100		Ω
I2C Input	3.3		5	VDC
DIN Input	0		15	VDC
DIN Input Low	-0.3		0.5	VDC
DIN Input High	1.5		15	VDC
DOUT Maximum Current			3	A
DOUT Maximum Voltage			40	VDC
I/O Output Voltage	0		3.3	VDC
Analog Input Voltage			15	VDC
Analog Useful Range	0		5.1	VDC
Analog Resolution		1.44		mV
Pulse In Resolution		12		ns
Encoder Counters		32		Bits
Encoder Frequency			21	Mhz
RS232 Baud Rate			921,600	Bits/s
RS232 Time Out	10			ms
User Program Memory		128		KBytes
User Variable Memory		16		KBytes
User Program Execution Speed		100,000		Lines/s
Temperature Range	-40	40	+100	$^{\circ}$ C

Notes:

1. Current is limited by maximum temperature. Starting at 85 $^{\circ}$ C, the current limit is reduced on a slope with a maximum temperature of 100 $^{\circ}$ C, which will reduce the current to 0 amps.
2. RS232 format is 8Bit, No Parity and 1 Stop bit.

Warranty

Ion Motion Control warrants its products against defects in material and workmanship for a period of 1 year. If a defect is discovered, Ion Motion Control will, at our discretion, repair, replace, or refund the purchase price of the product in question. Contact us at sales@ionmc.com. No returns will be accepted without the proper authorization.

Copyrights and Trademarks

Copyright© 2015 by Ion Motion Control, Inc. All rights reserved. All referenced trademarks mentioned are registered trademarks of their respective holders.

Disclaimer

Ion Motion Control cannot be held responsible for any incidental or consequential damages resulting from use of products manufactured or sold by Ion Motion Control or its distributors. No products from Ion Motion Control should be used in any medical devices and/or medical situations. No product should be used in a life support situation.

Contacts

Email: sales@ionmc.com
Tech support: support@ionmc.com
Web: <http://www.ionmc.com>

Discussion List

A web based discussion board is maintained at <http://www.ionmc.com>

Technical Support

Technical support is available by sending an email to support@ionmc.com, by opening a support ticket on the Ion Motion Control website or by calling 800-535-9161 during normal operating hours. All email will be answered within 48 hours.